



STANDARD CONSTRUCTION

BODY:
26 GAUGE ASTM A-653 HOT-DIPPED GALVANIZED STEEL SHEET
INSULATED WITH R4 BOARD

STANDARD SIZES:

MODEL	WIDTH (W)	HEIGHT (H)	DEPTH (D)
FFRI17.5	17 7/8"	4 3/8"	21"
FFRI21	21"	4 3/8"	21"
FFRI24	24 7/8"	4 3/8"	21"

FEATURES

26 GAUGE GALVANIZED STEEL PROVIDES EXCELLENT CORROSION RESISTANCE AND LONGEVITY.

SINGLE PIECE BODY CONSTRUCTION FOR ADDED STRENGTH.

FILTER TRACK CAN BE CONVERTED TO ACCOMMODATE A 2" FILTER, OR A 1" FILTER PLUS A 1" UV LIGHT SYSTEM.

RUBBER STRIPS MINIMIZE VIBRATION.

FULLY REMOVABLE ACCESS DOOR FOR EASY MAINTENANCE.

1" HOG HAIR FILTER WITH REINFORCED WIRES INCLUDED.

THE FFR FAMILY HAS BEEN DESIGNED FOR RHEEM AND RUUD AIR HANDLER UNITS. OTHER CUSTOM SIZES ARE AVAILABLE UPON REQUEST.

OPTIONS: CUSTOM SIZES AVAILABLE.

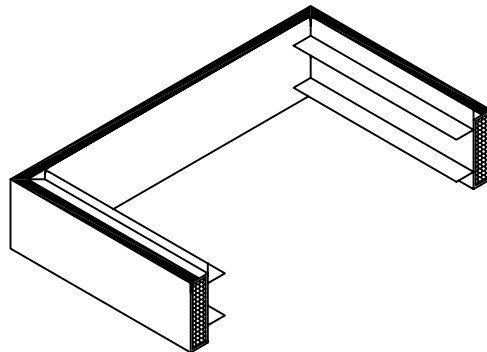
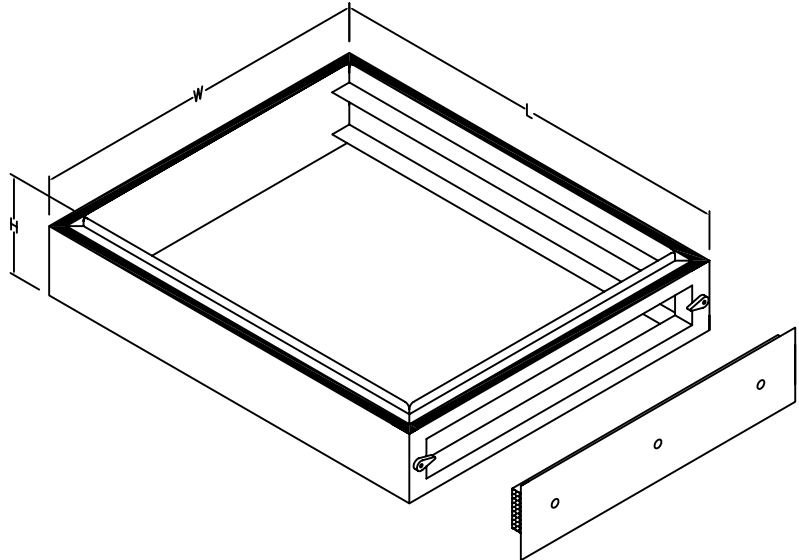

JOB NAME:
LOCATION:
ARCHITECT:
ENGINEER:
CONTRACTOR:
CONTACT MIAMI TECH INC. FOR ADDITIONAL INFORMATION OR WITH SPECIAL REQUIREMENTS. 3611 NW 74TH ST MIAMI, FL 33147 PHONE: 305-693-7054 FAX: 305-693-6152 WEB: WWW.MIAMITECH.COM EMAIL: SALES@MIAMITECH.COM

FFRI

**FIXED FILTER RACK FOR RHEEM/RUUD
PRODUCT SPECIFICATIONS**

NOTE: ALL DRAWINGS SUBJECT TO CHANGE WITHOUT PRIOR NOTICE.



DRAWN BY: AF	DATE: 08/20/07	SCALE: NOT TO SCALE	DRAWING NO.
CHECKED BY: IG	DATE: 08/20/07	REVISION: IG	

FFRI